

# OUTDOOR MEDIA GROUP, INC.

18611 SAUGAS AVENUE  
SANTA ANA, CA 92705

---

**BY EMAIL ONLY**

July 22, 2024

City of Corona  
Ms. Joanne Coletta  
Community Development Director  
400 S Vicentia Avenue  
Corona, CA 92882

[Joanne.Coletta@CoronaCA.gov](mailto:Joanne.Coletta@CoronaCA.gov)

## **Re: Billboard Relocation Request**

Dear Ms. Coletta:

Outdoor Media Group (“OMG”) is a family owned company located in Southern California and has been in the outdoor advertising business for decades. We currently own and operate an approximately 35 year old billboard located on the south side of the 91 Freeway, east of Green River, at APN 101-180-018. We have also acquired the rights to the second billboard on the same parcel. We would like to relocate both signs pursuant to § 17.74.070(H) of the Corona Municipal Code and Business and Professions Code § 5412 as follows:

**Existing Signs:** APN 101-180-018 (two double faced signs at 16 feet by 36 feet = 2304 square feet)

**Total Existing Square Footage:** 2304

**Relocation Site One:** 3035 Palisades Drive (double sided 14 feet by 48 feet each = 1344 square feet)

**Relocation Site Two:** 1450 Pomona Road (double sided 14 feet by 48 feet and 10 x 28 = 952 square feet)

**Total New Square Footage:** 2296

The relocation is being prompted by recent Caltrans construction which has resulted in the obstruction of the view of the existing billboards. In addition to a slight reduction in overall square footage, it is anticipated that there will be a reduction in the height above grade of the relocated signs.

Attached to this letter are the following:

A. Photographs of the existing billboards:

**EXHIBIT 2**

- B. Drawings of the proposed new billboards.
- C. Screen captures from Google Maps showing the approximate location of the proposed new billboards.

We have constructed more than 100 billboards in Southern California and Nevada during the history of our company and will submit appropriate structural plans and specification to the building department when requested. We hope that this letter and the attached material will be sufficient to begin the process of negotiating a relocation agreement.

In addition to the slight size and height reduction, we also intend to replace the old steel poles with a modern, square, masonry pillars, so that the new signs will be uniform in size and style with the other signs that have been the subject of relocation agreements. This will offer a benefit to the City by improving the aesthetic impact of the signage along the 91 in Corona by removing an old, non-conforming, metal structures and replacing with modern ones that conform to the other relocated billboards in size and style of construction.

We hope that the City will look favorable on our request and look forward to many more years of success in Corona. Please do not hesitate to contact us if you have any question or concerns or require any additional information.

Sincerely,

/s/ Jon Gunderson  
Jon M. Gunderson, President

## **ATTACHMENT A**



**Weir Canyon  
Honda**



**Weir Canyon  
Acura**



**Exit North on Weir Canyon** →



## **ATTACHMENT B**

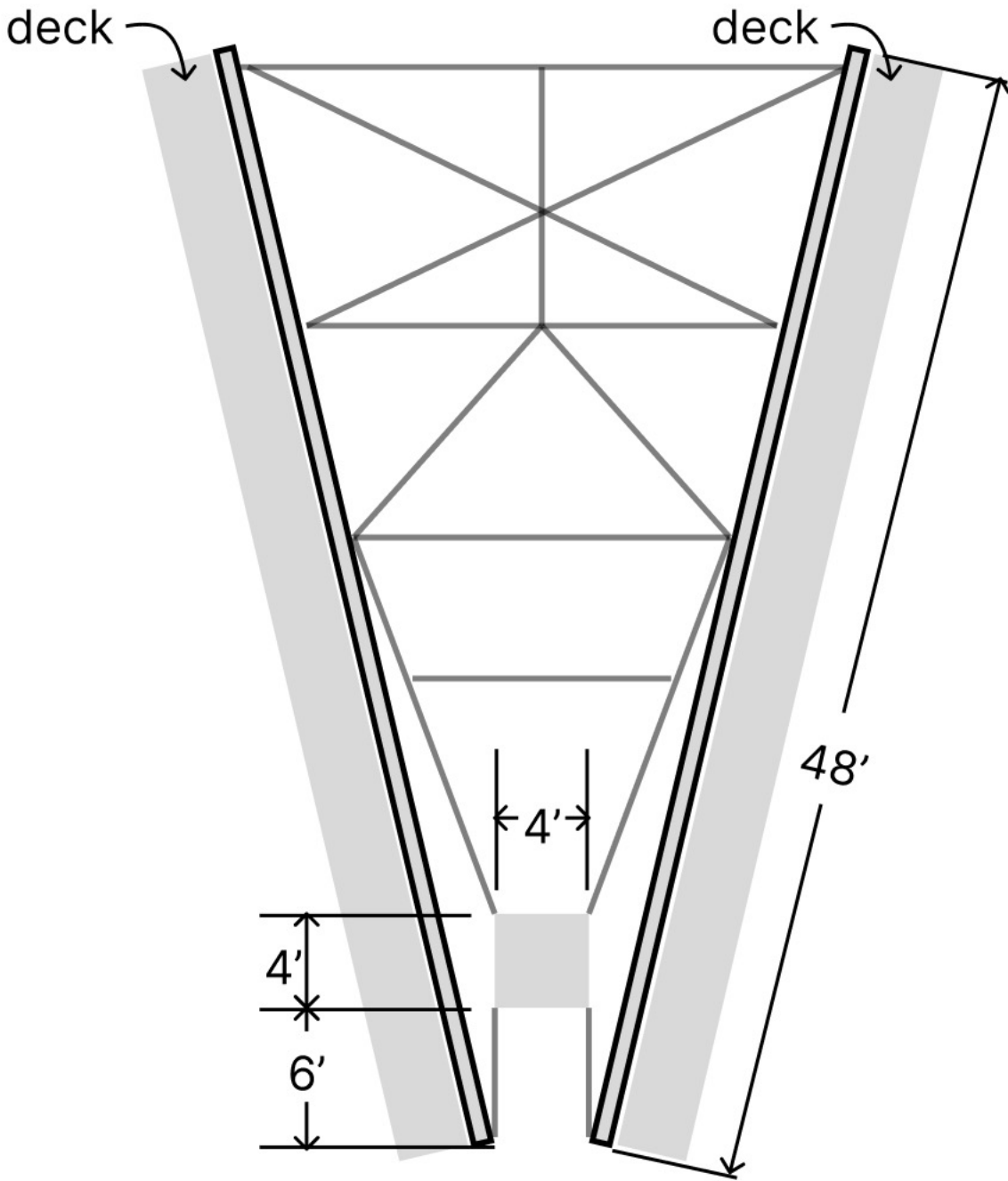

Top View

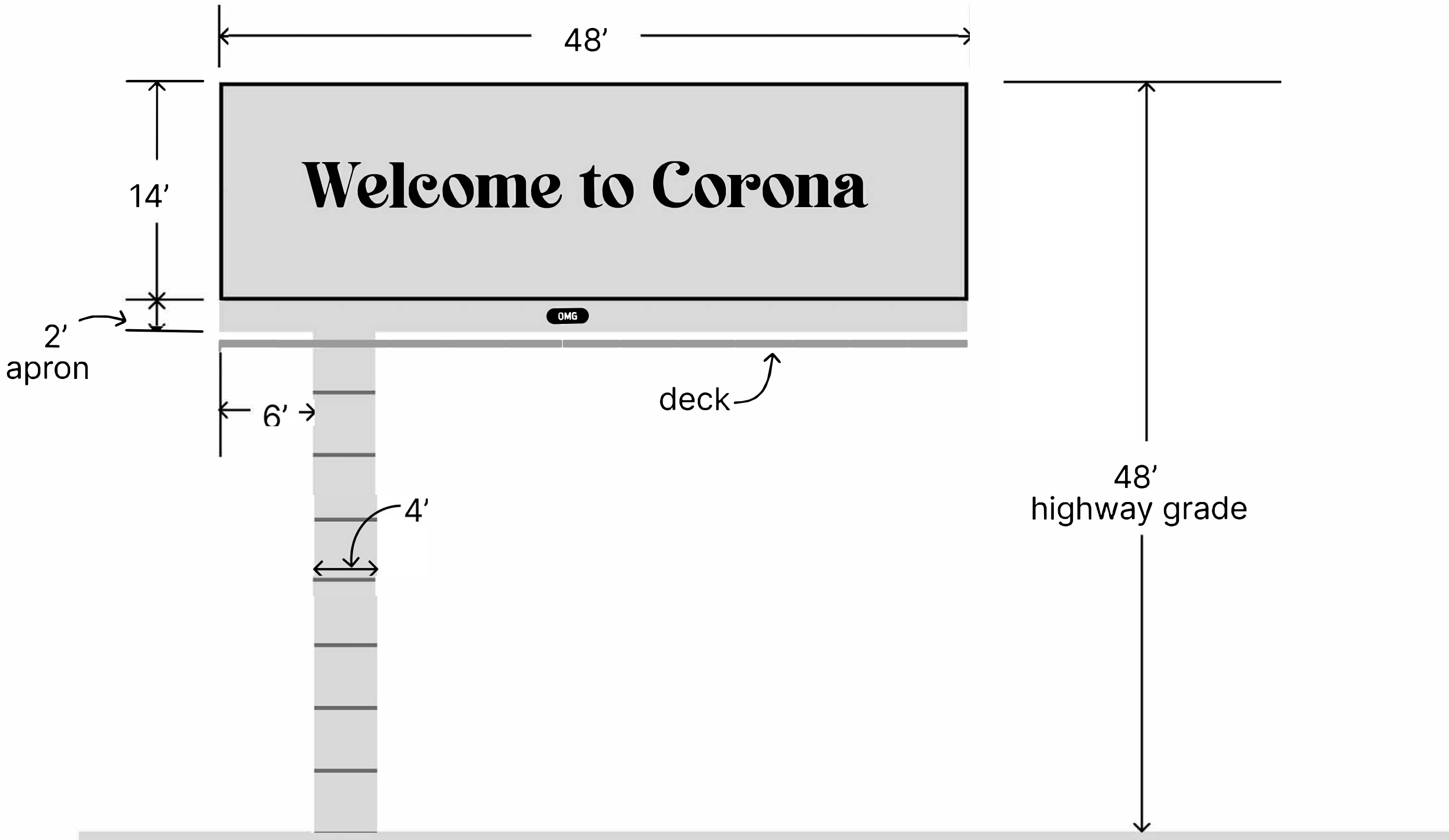

Front Elevation



**ATTACHMENT C**

**Relocation Site One:**

3035 Palisades Drive

(West Face 14 x 48)

(East Face 14 x 48)

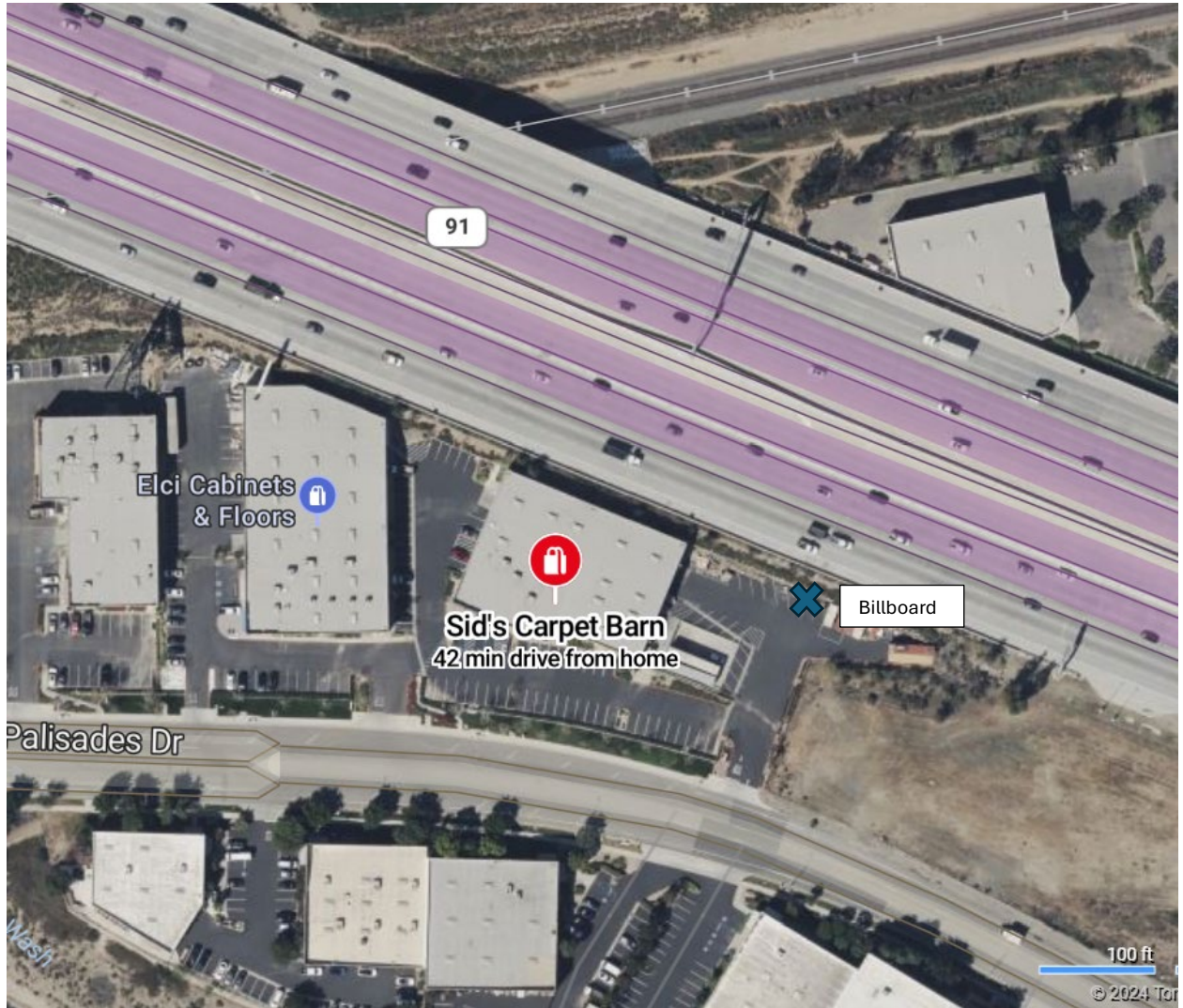

**Relocation Site Two**

1450 Pomona Road

(West Face 10 x 28)

(East Face 14 x 44)

